

# High Voltage Transformer

TYPE:TR09-S012 UU42

## Applications:

- AIR CLEANER.
- ELECTRONIC OZONIZER.
- ELECTROSTATIC PRODUCTS.
- RANGE HOOD.

※Remark:Below here which specific could depend on customized specifications are acceptable.

MECHANICAL DIMENSION:

UNIT mm

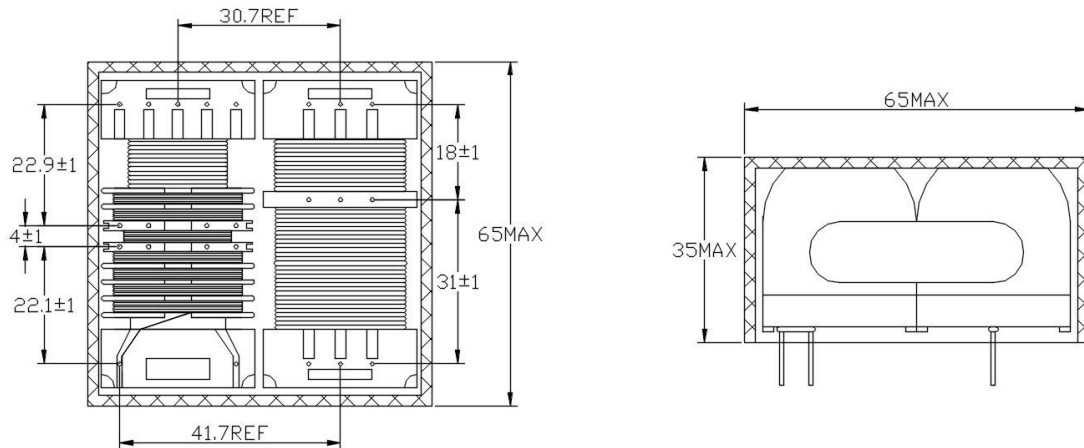

P/N	L <sub>pri.</sub> (PIN1→PIN5)	L <sub>pri.</sub> (PIN6→PIN7)	L <sub>sec.</sub> (PIN3→PIN7)	L <sub>sec.</sub> (PIN1→PIN9)	L <sub>sec.</sub> (PIN10→PIN11)	TURNS RATIO	WEIGHT
JC-101022	660μH±15%		960mH±15%			1:37	250 g
JC-92104	1.0mH±20%	4.1μH±20%		2.0H±20%	2.0H±20%	65:4:2750×2	260 g
JC-103021	410μH±20%		140μH±20%	10.8H±15%		1:285	260 g

## JET CHAM ENTERPRISE CO.,LTD

ADDRESS: 3F. NO.41 CHIAU AN ST. CHUNG HO DIST .NEW TAIPEI CITY,  
TAIWAN R.O.C.

OFFICE TEL:886-2-29253396 ~ 7 FAX.:886-2-29288877

FACTORY TEL:886-2-22447326 ~ 7 FAX.:886-2-22447328

E-mail: [jetcham@ms35.hinet.com](mailto:jetcham@ms35.hinet.com) / [jetcham.coil@msa.hinet.net](mailto:jetcham.coil@msa.hinet.net)